



We Build Better.™

MaxFlo® XL

High Efficiency Pumps

ADVANCED HYDRAULICS FOR MORE EFFICIENT PERFORMANCE

Aligns with the entire MaxFlo® line for seamless retrofit installations

Clear strainer cover seals with less than a ¼ turn and lets you see when the basket needs cleaning

1½" x 2" union connections in all models

Advanced hydraulics for increased energy efficiency and priming ability



Superior pump efficiency meets Department of Energy regulations

Easy 4-bolt access makes servicing simple

Heavy-duty motor provides performance you can trust

Optional riser base (SPX2300GR) provides alignment with Sta-Rite® Dyna-Pro®



SPECIFICATIONS

MODEL NUMBER	TOTAL HORSEPOWER	SERVICE FACTOR	VOLTAGE	WEIGHTED ENERGY FACTOR (WEF)*	UNION CONNECTIONS	DIMENSION "A"	CARTON QUANTITY	CARTON WEIGHT
SP2305X7	0.95	1.00	115/208-230	4.3	1½" x 2"	13¾"	1	34 lbs.
SP2307X10	1.25	1.00	115/208-230	3.8	1½" x 2"	14¼"	1	37 lbs.

*The higher the weighted energy factor (WEF), the more efficient the pump. Visit hayward.com/regulations for more information.

MAXFLO XL DIMENSIONS (INCHES)

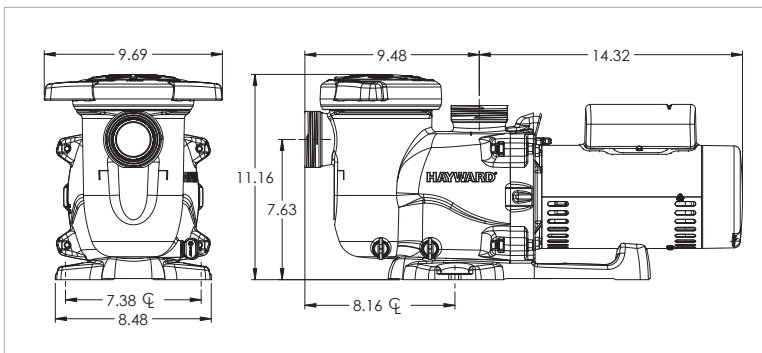

MAXFLO XL MEDIUM HEAD PUMPS

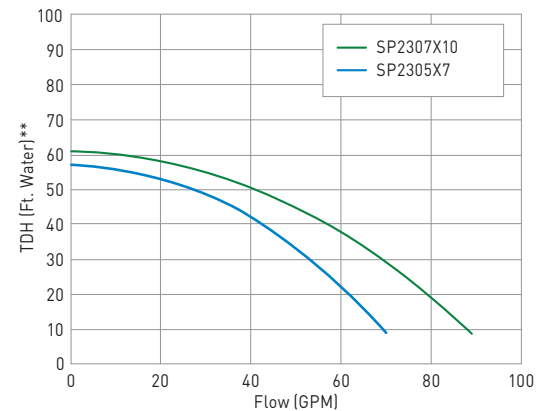

**2.31 Feet of Water = 1 PSI

MaxFlo XL series pumps are listed by:

» hayward.com » 1-888-HAYWARD | Pumps » Filters » Heaters » Sanitization » Automation » Lighting » Water Features » Cleaners » Safety

Hayward, Hayward & Design, the H logo and MaxFlo are registered trademarks and We Build Better, is a trademark of Hayward Industries, Inc. ENERGY STAR is a registered mark owned by the U.S. government. All other trademarks not owned by Hayward are the property of their respective owners. Hayward is not in any way affiliated with or endorsed by those third parties. © 2021 Hayward Industries, Inc.

eLITMFXL21