



## MaxFlo VS™ 500

»» Variable-Speed Pump

DURABLE DESIGN.  
SUPERIOR SAVINGS.



EXPERT LINE



PREMIUM PRODUCTS



NOT SOLD ONLINE



EXTENDED WARRANTIES

**Intuitive control pad** can be rotated in four directions on the pump or removed and wall mounted

**See-through strainer cover** lets you see when the basket needs cleaning

**1 1/2" x 2" union connections** allow for seamless installation in any application

**Advanced hydraulic design and self-priming capability** create suction lift up to 8' above water level



**UNRIVALED RELIABILITY**

A chemical-resistant Viton® seal and a 3-year warranty mean MaxFlo VS™ 500 will provide years of powerful performance.

**ENERGY-EFFICIENT DESIGN**

With a super-efficient permanent magnet, totally-enclosed fan-cooled motor, MaxFlo VS 500 provides up to 80% energy savings over single-speed pumps and pays for itself faster than larger, more expensive models.

**UNIVERSAL COMPATIBILITY**

MaxFlo VS 500 is an easy, drop-in upgrade that can operate in standalone mode or connect to any automation system, either directly or with relays.



**SPECIFICATIONS**

MODEL NUMBER	STAND ALONE	RELAY CONTROL	HAYWARD® AUTOMATION	TOTAL HP	VOLTAGE
SP23520VSP	•	•	•	1.65	230V Single Phase
SP23510VSP*	•	•		0.85	115V Single Phase

**MAXFLO VS 500 DIMENSIONS (INCHES)**

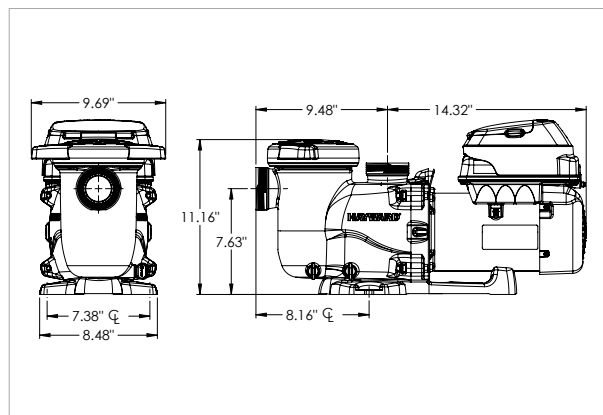

\*Available with automation as of July 2018.

**MAXFLO VS 500 PERFORMANCE COMPARISON**

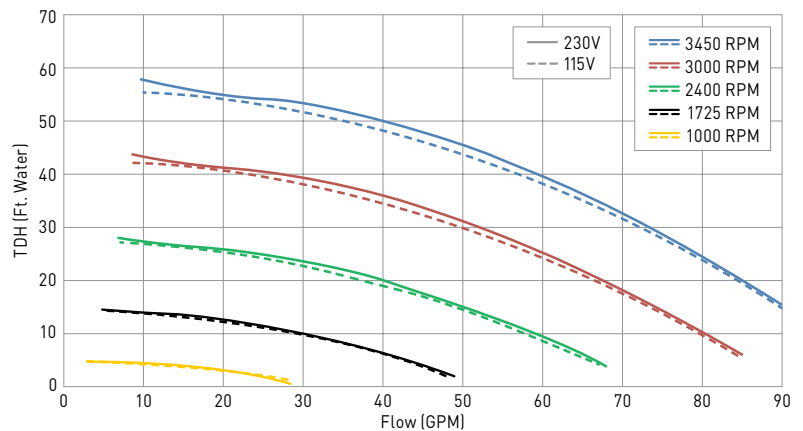

» hayward.com » 1-888-HAYWARD

MaxFlo VS 500 pumps are listed by: NSF c UL us

Pumps » Filters » Heating » Cleaners » Sanitization » Automation » Lighting » Water Effects » White Goods

Hayward is a registered trademark and MaxFlo VS is a trademark of Hayward Industries, Inc. © 2018 Hayward Industries, Inc. ENERGY STAR is a registered mark owned by the U.S. government.

LITMFVS500S18

