

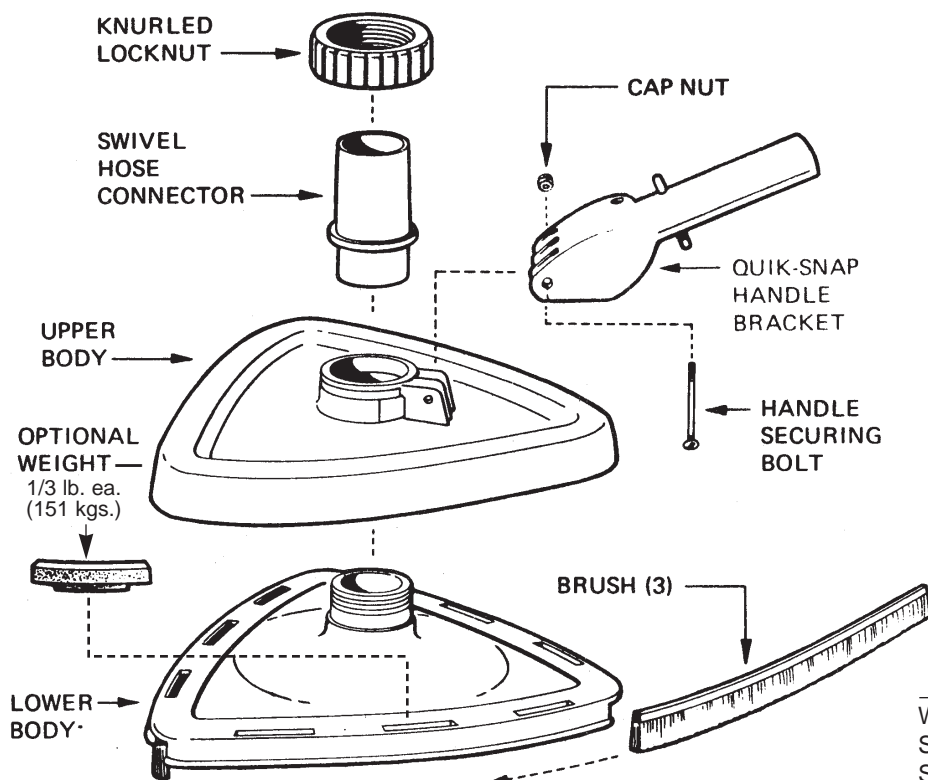

SUPER★VAC™

MODELS SP1068 and SP1068 DL



FEATURES:

- Smooth, contoured shape for efficient vortex cleaning on straight-aways and corners.
- Molded of luxurious transparent Dural™ plastic. Lets you see thru head when vacuuming.
- Adjustable weight. Just add or remove internal weights to suit your preference. (Range 40 to 88 oz.)
- 360° swivel hose connector for easy maneuverability and no hose tangling.
- Easily cleanable, long-wearing brushes.

MODEL SP1068DL—Furnished with Three (3) 1/3 lb. weights.

MODEL SP1068—Furnished Less Optional weights.

PART NO. SP1068FA—Weight Pak - Includes Three (3) 1/3 lb. weights.

WEIGHT

Super Vac without weights - 2-1/2 lbs. (1.135 kgs.)

Super-Vac with 3 weights - 3-1/2 lbs. (1.589 kgs.)

Maximum weight (9 weights) - 5-1/2 lbs. (2.497 kgs.)

INSTRUCTIONS

Your Super-Vac is designed in two basic main parts for ease of assembly and disassembly—an upper body and lower body. They are joined together by a knurled locknut.

To disassemble the upper and lower bodies, simply unscrew the locknut (counterclockwise) and separate the two parts.

To assemble, fit the upper and lower bodies together and secure with the locknut. **DO NOT OVERTIGHTEN LOCKNUT.**

1. **Install Swivel Hose Connector.** Remove locknut and insert hose connector. Screw on locknut to secure. Be sure connector swivels freely. Do not overtighten.
2. **Assemble Handle Bracket** to vacuum head and secure with bolt and cap nut.
3. **Optional Weight Adjustment.** The lower body has slots to receive the tab of the optional weights, and the upper body has pockets to hold them in position. For most applications where a “heavier” vacuum is desired, three (3) weights are enough. Position one each of the weights in the center pocket on each of the

three sides of the vacuum. Additional weights may be added to suit your preference. They are available from your dealer in 3-paks and your Super-Vac can accommodate up to nine weights.

With use and some experimenting, you will quickly find the best weight and weight positions for your particular pool .

SOME TIPS . . .

1. Generally a “lighter” vacuum (approx. 40 oz.) requires less effort to use.
2. With larger pumps, first try without weights.
3. With small pumps, use the “weighted” vacuum.
4. If vacuum “feels hard to move,” take out the two “side” weights.
5. If front of vacuum lifts during “fast” vacuuming, add a weight to the front.

To Remove Brushes for cleaning or replacement—separate upper and lower bodies, and slide brushes out of retaining grooves in lower body.



HAYWARD POOL PRODUCTS, INC.

Hayward Pool Products, Inc.
900 Fairmount Avenue
Elizabeth, NJ 07207

Hayward Pool Products, Inc.
2875 Pomona Boulevard
Pomona, CA 91768

Hayward Pool Products Canada
2880 Plymouth Drive
Oakville, Ontario L6H 5R4

Hayward S.A.
Zone Industrielle de Jumet
B - 6040 Charleroi (Belgium)